

TCORX
PROFESSIONAL LINE

INSTRUCTION



TRX 9000



Cod : TOXPRFTRX9000

Rev : 00

Ed : 10/18



Hardware and tool

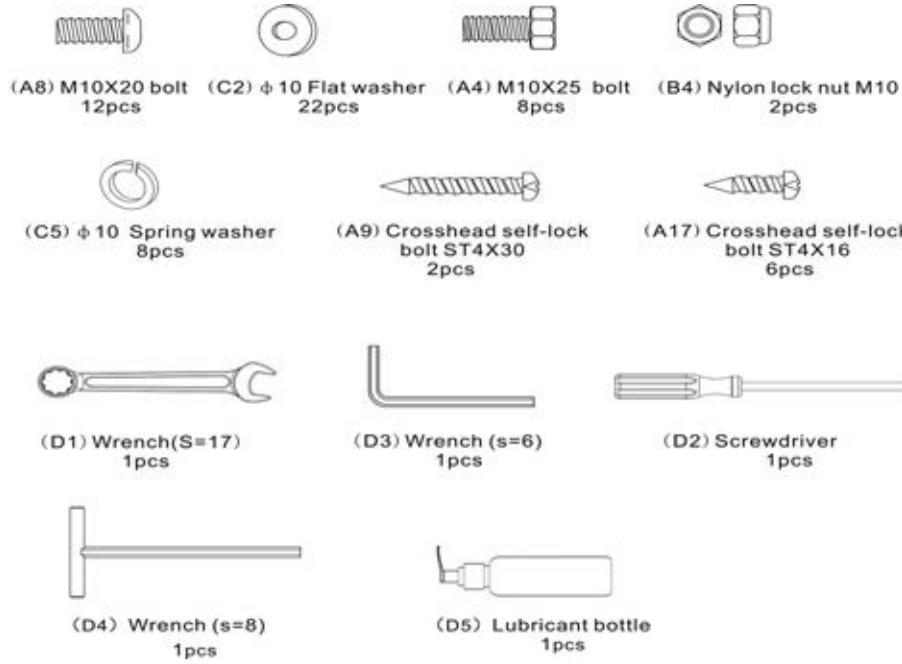

Exploded drawing

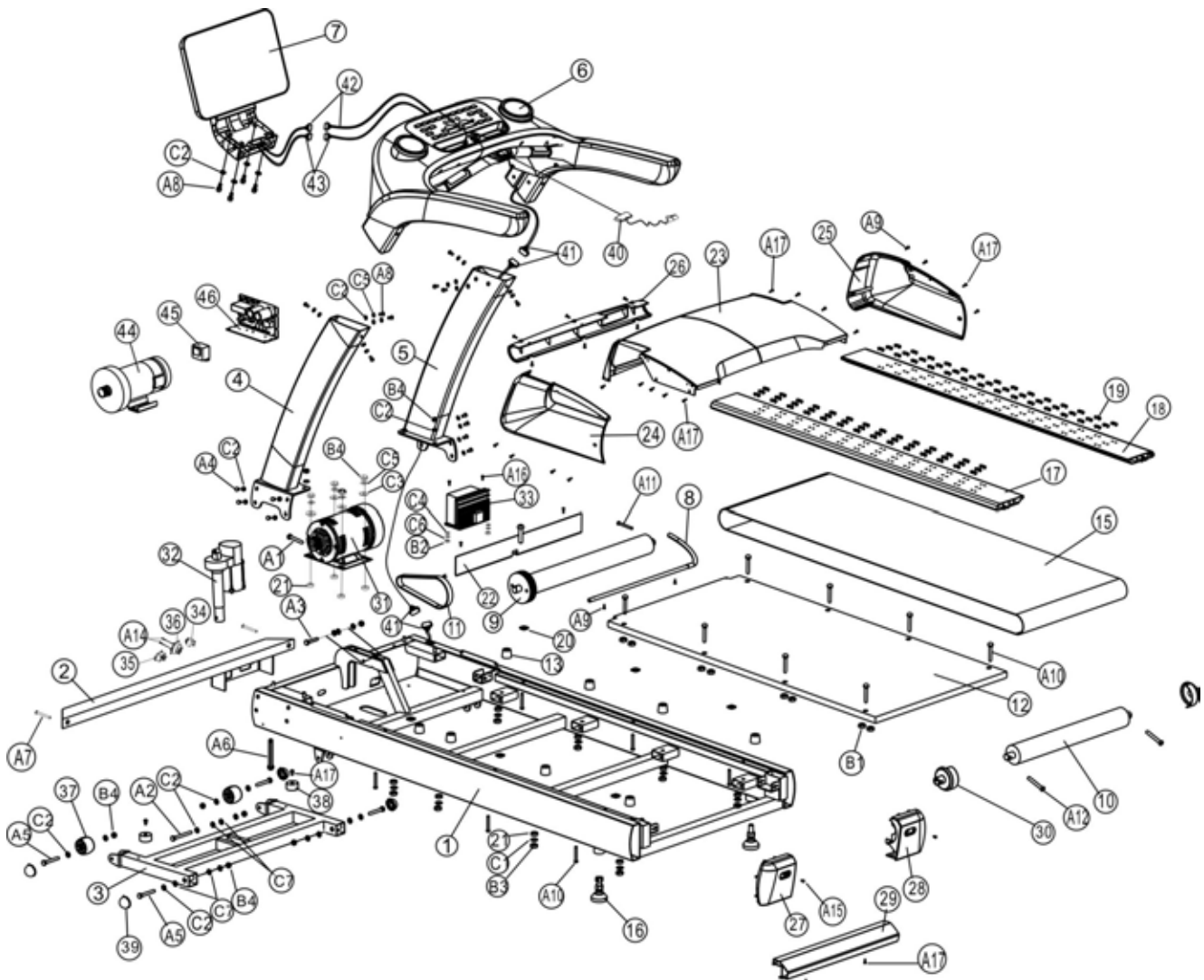

Spare Parts List

No.	Description	Qty
1	Base frame	1
2	Switch base frame	1
3	Incline frame	1
4	Left upright tube	1
5	Right upright tube	1
6	Handlebar and controller	1
7	Display screen	1
8	Oil pipe	1
9	Front roller	1
10	Rear roller	1
11	10 V belt	1
12	Running board	1
13	Running board cushion	8
14	Rubber mat	8
15	Running belt	1
16	Universal wheel mat	2
17	Left side rail	1
18	Right side rail	1
19	Non-slip colloidal particles	84
20	Position nut	6
21	Shock absorption mat	4
22	Baffle plate	1
23	Motor top cover	1
24	Motor left cover	1
25	Motor right cover	1
26	Motor front cover	1
27	Left end cap	1
28	Right end cap	1
29	Middle end cap	1
30	Rear roller cap	2
31	Motor (AC)	1
32	Incline motor	1
33	Frequency changer (AC)	1
34	Emergency stop switch	1
35	Cymbiform switch	1
36	socket	1
37	wheel	2
38	cushion	2
39	Nut cap	4
40	Safety key	1

No.	Description	Qty
41	Signal wire A	3
42	Signal wire B	2
43	Signal wire C	2
A1	Bolt M8X55	1
A2	Bolt M10X95	1
A3	Bolt M10X55	1
A4	Bolt M10X25	8
A5	Bolt M10X75	4
A6	Bolt M10X165	2
A7	Half-round bolt M8X20	2
A8	Half-round bolt M10X20	10
A9	Crosshead self-lock bolt ST4X30	4
A10	Half-round bolt M8X45	6
A11	Round bolt M10X60	2
A12	Round bolt M10X90	2
A13	Crosshead bolt M8X70	8
A14	Crosshead bolt M3X8	2
A15	Crosshead bolt M5X40	2
A16	Crosshead bolt M5X20	2
A17	Crosshead self-lock bolt ST4X16	27
B1	Hexagon Nut M8	8
B2	Nylon lock nut M5	2
B3	Nylon lock nut M8	8
B4	Nylon lock nut M10	14
C1	Flat washer ϕ 8	8
C2	Flat washer ϕ 10	24
C3	Big flat washer ϕ 10	4
C4	Flat washer ϕ 5	2
C5	Spring washer ϕ 10	10
C6	Spring washer ϕ 5	2
C7	Nylon Washer ϕ 10	4
D1	Wrench	1
D2	Screwdriver	1
D3	Wrench (s=6)	1
D4	Wrench (s=8)	1
D5	Lubricant bottle	1

Assembly Instruction

Please make sure there's enough space to install the treadmill and recommend 2 persons to install it.

WARNING: Don't insert the power wire until the treadmill was fully assembled.

Assembly tips:

1. In order to avoid instruction mistake, do not tighten bolt completely until the whole treadmill assembly is finished.
2. This treadmill packaged for 2 cartons. #1 carton is main frame. #2 carton is Handlebar and controller.

1. Opening the package and take the base frame out

Before the treadmill leave the factory, the frame and pallet were fixed by holders and bolts. Using wrench to unscrew the bolts (total 4pcs bolts) on frame, then take the base frame out. (See figure 1)

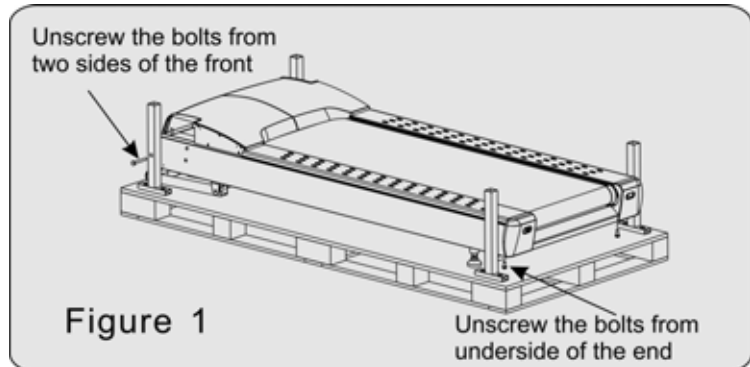

2. Assembling left upright tube

A. Install the Left upright tube (4) to base frame (1) using four sets of bolt M10X25 (A4), Flat washers $\phi 10$ (C2) by side. (Attention: to align screw hole with the upper surface). Make sure the bolts to connect left upright tube and base frame. (See figure 2)

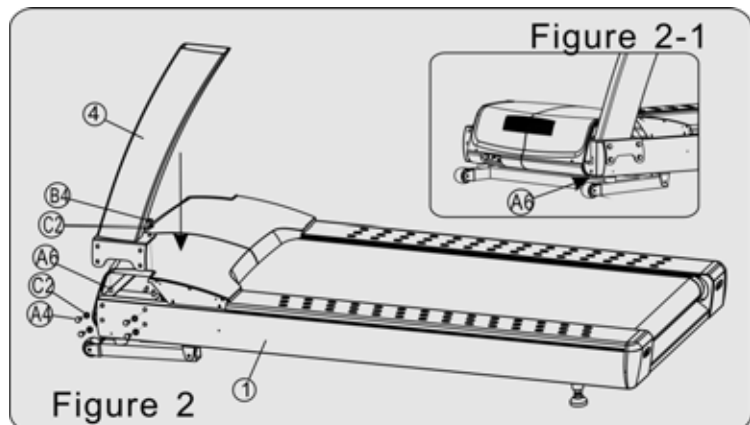

B. In upper inner side, using one piece Flat washer $\phi 10$ (C2) and one piece Nylon lock nut M10 (B4) to tighten. In upper outer side, using Bolt M10X165 (A6) that was assembled on frame to tighten. (Attention: bolt head position is the front underside. See figure 2-1)

3. Assembling right upright tube

A. Connect the Signal wire from right upright tube to corresponding wires from frame.

B. Install the Right upright tube (5) to base frame (1) using four sets of bolt M10X25 (A4), Flat washers $\phi 10$ (C2) by side. (Attention: to align screw hole with the upper surface). Make sure the bolts to connect left upright tube and base frame. (See figure 3)

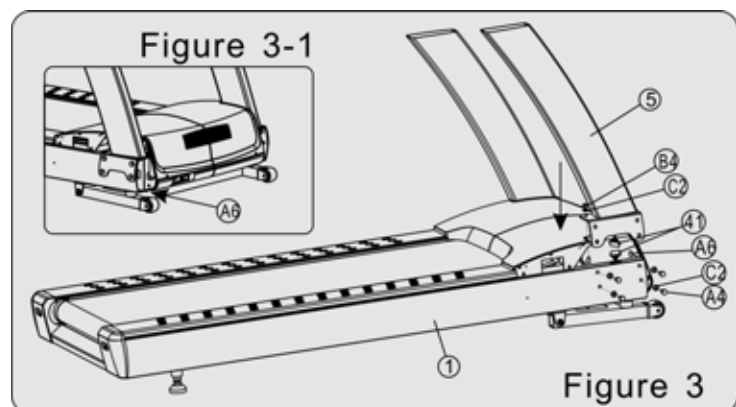

C. In upper inner side, using one piece Flat washer $\phi 10$ (C2) and one piece Nylon lock nut M10 (B4) to

tighten. In upper outer side, using Bolt M10X165 (A6) that was assembled on frame to tighten.(Attention: bolt head position is the front underside. See figure 3-1)

4. Assembling handlebar and controller

A. Connect the Signal wire from Right upright tube to corresponding wires from Handlebar.

B. Install handlebar and controller set(6) to the Left/Right upright tube (4,5).

C. Connect handlebar and controller(6) to the Left/Right upright tube (4,5) using 8 sets of Half-round bolt M10X20(A8),Spring washer ϕ 10(C5),Flat washer ϕ 10(C2). (Attention: To align screw hole)(See figure 4)

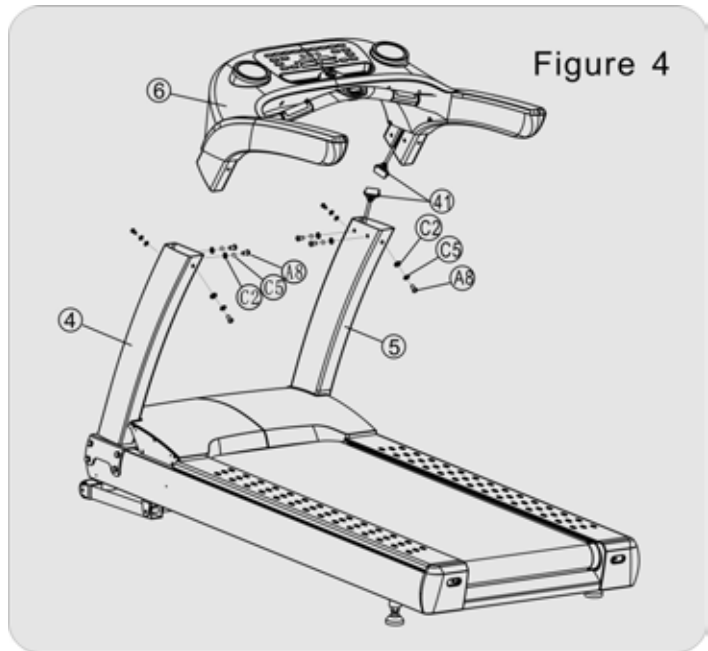

5. Assembling display screen

A. Connect the signal wire from display screen to corresponding wire from controller. Crowding the extra wire into controller.

B. Connect the display screen (7) to handlebar and controller (6) using 4 sets of Half-round bolt M10X20(A8),Flat washers ϕ 10(C2).(Attention: To align screw hole)(See figure 5)

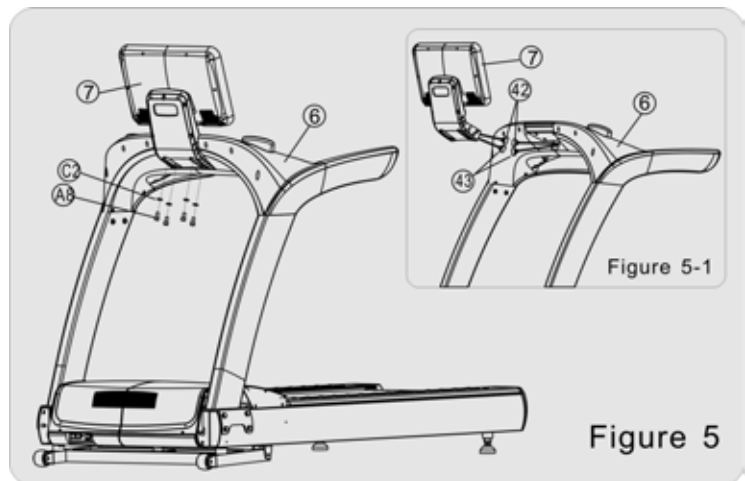

6. Assembling motor left & right cover

A. Tighten all the assembling bolt.

B. Install motor left cover (24) to left motor cover (23) of base frame (1) using 1pcs Crosshead self-lock bolt ST4X30 (A9) in front and 3pcs Crosshead self-lock bolt ST4X16 (A17) to tighten.

C. Install motor right cover(25) to left motor cover(23) of base frame (1) using 1pcs Crosshead self-lock bolt ST4X30 (A9) in front and 3pcs Crosshead self-lock bolt ST4X16(A17) to tighten.(See figure 6)

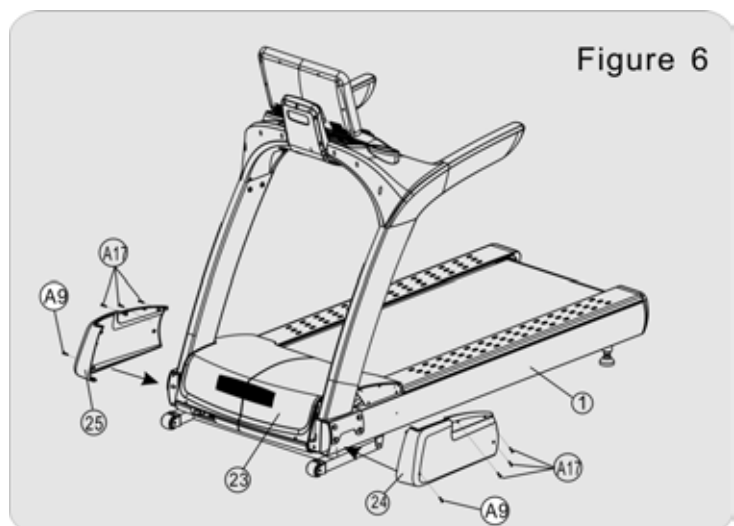

Adjustment instruction

Treadmill adjustment

1. Before connect power, service or professional inspect if voltage is suitable, and if three-core plug grounded wire is connected. Using hand to pull the belt, inspect if rotation is flexible and no noise.
2. Connect power, press Start key, treadmill will run slowly, inspect if belt and computer are normal.
3. Press incline +/- key, inspect treadmill rotation and display. If the belt is deviation, you must stop it to adjust belt according daily maintenance.
4. Pressing emergency stop key or pull out safety key on running treadmill, it will stop immediately. Rotating the emergency stop key to reset or insert safety key, can restart treadmill.
5. Press Stop key, the treadmill stop to running, waiting incline back to zero class, turn off the power.

Treadmill can use after all the install adjustment is finished.

1. Two feet stand on two side of belt, put the other side clip from safety key to clip to clothes. (see figure)
2. Press Start key, the treadmill will run slowly. You can step on belt slowly.
3. Press speed+ key, the belt speed will gradually increase, you can see the speed data from computer, after run is suitable, you can let go handrail to run.
4. When stop running, should gradually slow, and run 2-3 minutes in slow speed, put the heart and breathe back to normal.
5. At the end of run, you can reduce belt speed to the lowest, and the treadmill will stop when pressing stop key.
6. If it is too late to reduce speed and lose balance when high speed running, you can press and pat the emergency key, treadmill will stop to run immediately. Its stopped distance according to inertia and weight.
7. Please fully master emergency key and safety key usage.

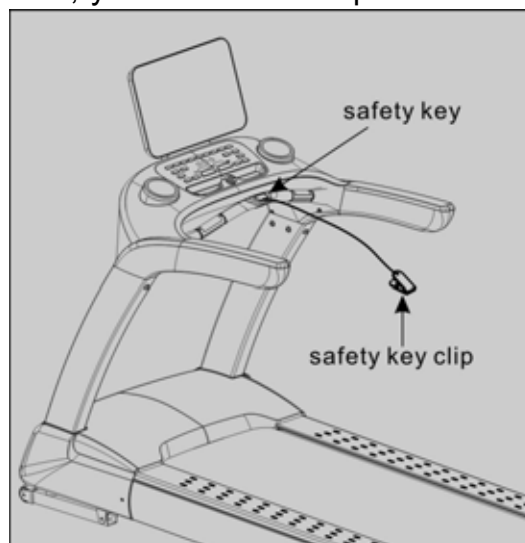

Computer Instruction

1.Function



Display screen	LED+Dot-matrix display screen	Shortcut keys	Incline direct shortcut key:4-8-12 Speed direct shortcut key:3-6-9
Running data	Time, Incline, Speed, Pace, calories, distance, Heart rate, R-steps, Mets, Environment temperature	Sound technology	Build-in double track surround speaker 5W2 PCS
Pulse monitor	Hand Pulse, HRC wireless heart rate (if have)	Audio and video format	Support audio and video multiple format player
Intelligent exercise program	Heart Rate Control Program, Custom Program, Manual Program, Target Setting Program, Hill Climbing Program, Fat burn Program, Cardio Program, Strength Exercise Program, Fit test Program	Transport Interface	3.5mm audio interface/ USB3.0 interface
		Press-to-select equipment	Physical rubber buttons





2.Controller instruction





2.1 Physical rubber buttons control console (see figure as below)



2.1.1 Buttons function table

Button Icon	Button Name	Button Instruction
■ Treadmill operation key instruction		
	START Key	Connect the power, press START key, the treadmill start running.
	STOP/PAUSE Key	When treadmill running, press STOP/PAUSE to pause status, press it again, the treadmill turn to stop status. After pause, press Start key, treadmill back to the front of pause status.

	CLEAR Key	Press this key to confirm to clear after setting.
	Safety Key	It is an emergency stop device to prevent slip. Please clamp to your clothes when using the treadmill. Pull the string or pat the safety key button, treadmill will stop immediately, matrix display shows “---” icon. It must be push the safety key slice if you need to start treadmill.
Right	Speed adjust key	When the treadmill running, press them to adjust speed, long press quickly adjustment; you also can press this key to increase speed value in the direct select exercise program.
	Speed direct key	Hold-in 3-6-9 three speed direct shortcut keys. (It is effective when the treadmill running)
Left	Incline adjust key	Press quickly adjustment, you also can press this key to increase speed value in the direct select exercise program.
	Previous song/ volume down	Press one time to back previous song, long press to volume down.
	Pause/Stop key	Press one time to play, press again to pause.
<p>■P1-P9 9 kinds of intelligent exercise program direct select instruction.</p>		
	P1:Heart Rate Control Program	Level 1, long distance running and speed training; Level 2, endurance and stamina training; Level 3, interval running training; Level 4, strength training before the game.
	P2:Custom/PTCSEL Program	1) Physical compliance training program; 11-12 Body fitting program; 13-15 Physical fitness maintaining program; 18 Physical recovery program. 5 custom programs.
	P4:Target Setting	Target training program: you can set exercise intensity (Mets) as

	Program	target training program.
	P5:Hill Climbing Program	Three kinds of different incline hill climbing program. It can be strengthen limbs and muscle training from gentle slope to steep slope.
	P6:Fat burn Program	Three kinds of timing fat burn training program: p1 training time of 20 minutes; p2 training time of 30 minutes; p3 training time of 60 minutes.
	P7:Cardio Program	Three kinds of countdown cardio training program: RPE-1 60 minutes of the countdown training; RPE-2 30 minutes of the countdown training; RPE-3 10 minutes of the countdown training.
	P8:Strength Exercise Program	Five level of strength exercise program:LEVEL-1 Easy run; LEVEL-2 Marathon target pace running; LEVEL-3 Tempo running; LEVEL-4 interval running; LEVEL-5 Repeats running.
	P9:Fit test Program	After enter into the Fit test program , it will countdown 30 seconds for fit test program: fat percentage (Distance window display); Basal metabolism rate (Speed window display); Body Mass (Rise window display) .

3. Display screen and console

3.1 Display screen and console instruction



3.2 Display screen instruction

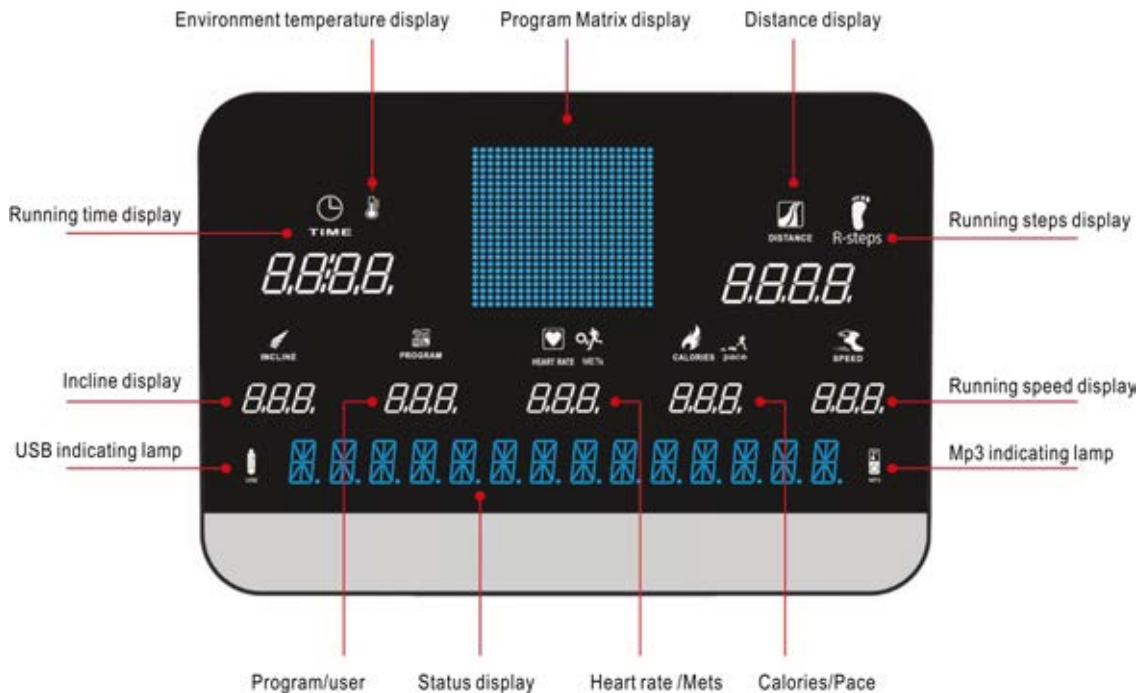

4. Operation instruction

4.1 Treadmill operation instruction

4.1.1 Standby mode operation

Put the special power wire insert to treadmill socket, another end of power wire has be connected to the environment working voltage (environment working voltage must be in conformity with requirements of the treadmill). Connect the power, treadmill enter to standby mode, time window shows environment temperature, PROGRAM window shows setting program ,other windows will shows initial value “0”.

4.1.2 Start treadmill operation

In standby mode, press START key, treadmill start to running, each window will show current exercise data accordingly. Matrix window display current position and tracks, length of track 400 meters. At the same time, you can select speed or incline key to adjust speed or incline class as you like, press stop key to pause or stop running.

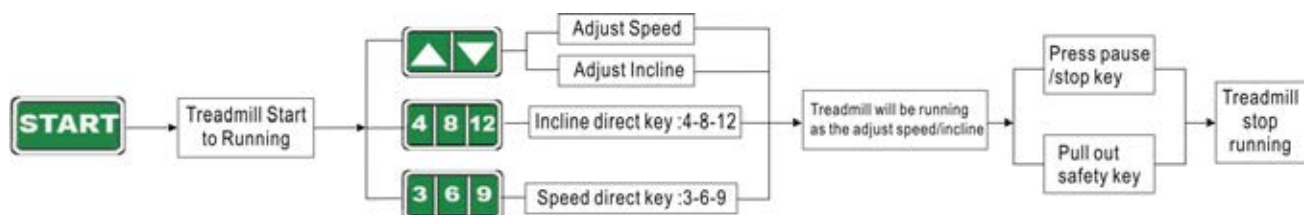

4.1.3 Exercise program operation instruction

Treadmill used 9 kinds of intelligent exercise program. According to user’s age, gender, weight etc, and user’s exercise purpose to customize. Exerciser according to intention to choose a appropriate exercise program training.

When you use intelligent program, you need to use setting key to precede relevant setting, press Enter key to confirm; press Clear key to modify setting; Press P1-P9 direct key to select intelligent program as you like, press Stop/pause key to exit when selected, then you can select another intelligent program after exit.

4.1.4 Intelligent Exercise program operation schematic diagram

P1: Heart Rate Control Program

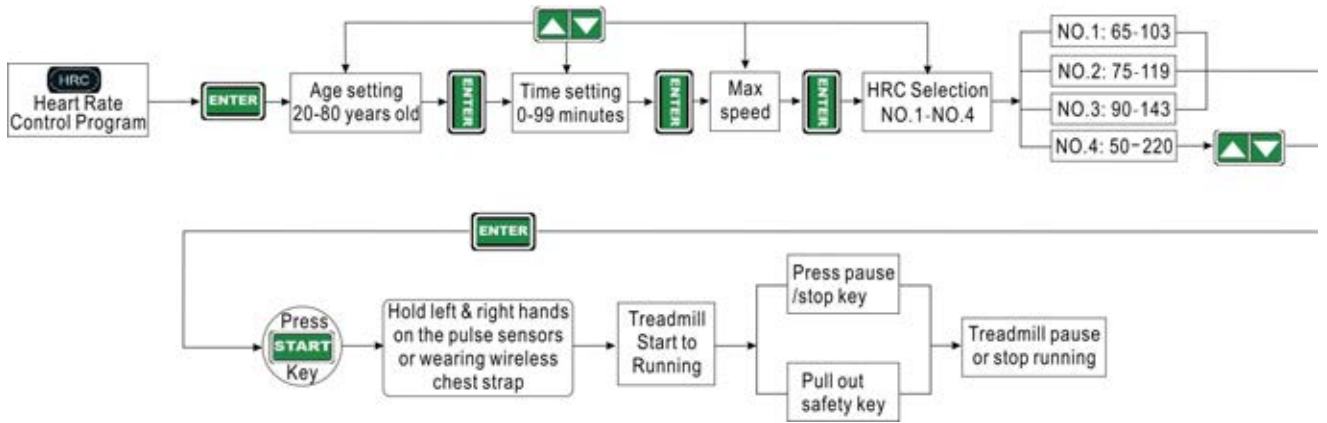

P2: Custom Program

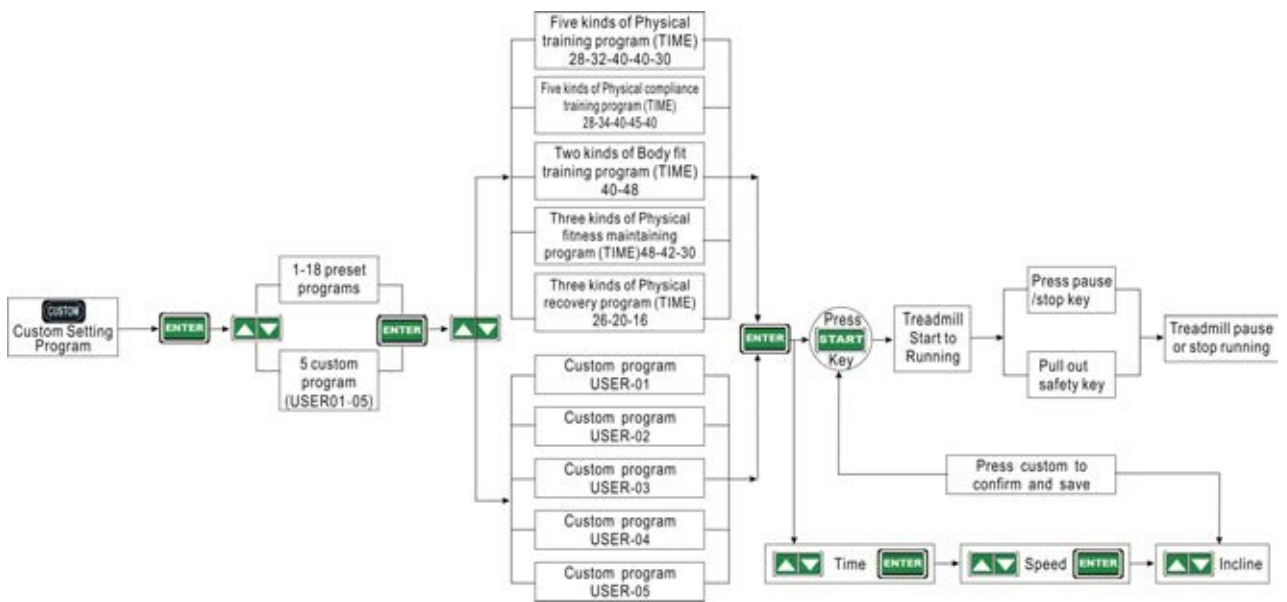

P3: Manual Program

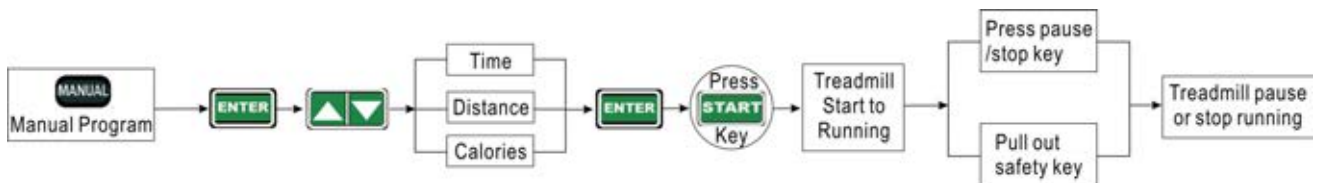

P4: Target Setting Program

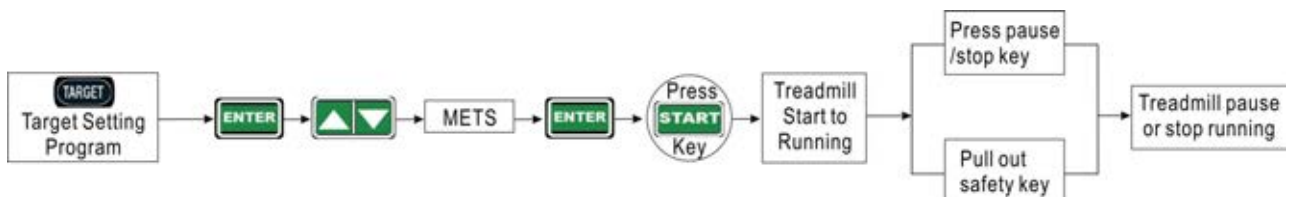

P5: Hill Climbing Program

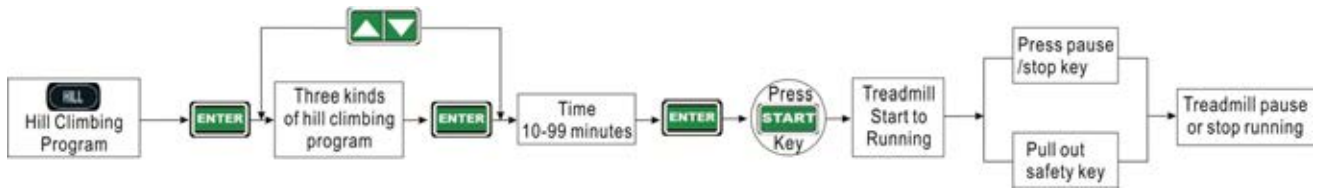

P6: Fat burn Program

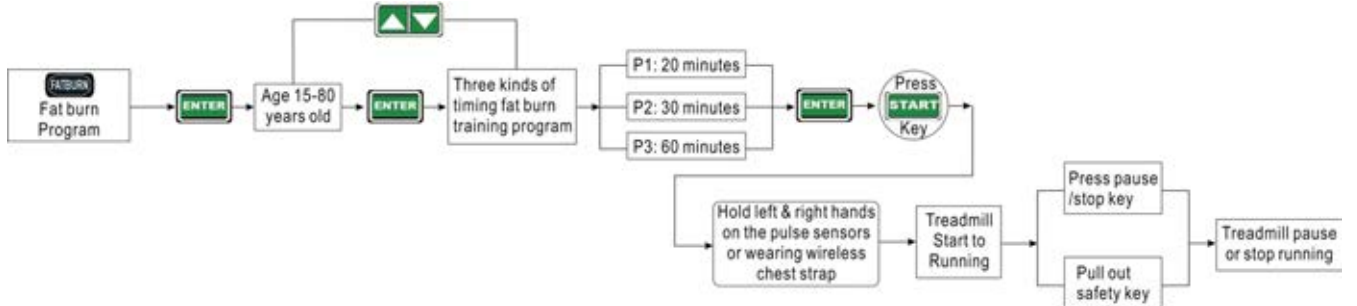

P7: Cardio Program

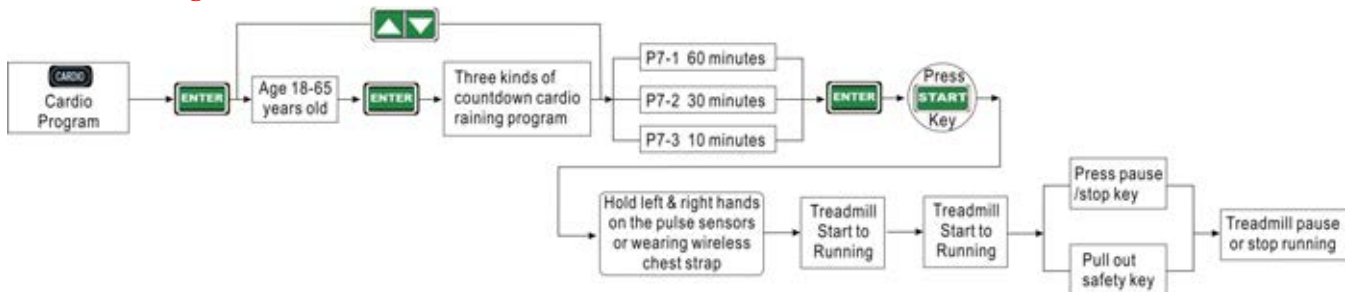

P8: Strength Program



P9: Fit test Program

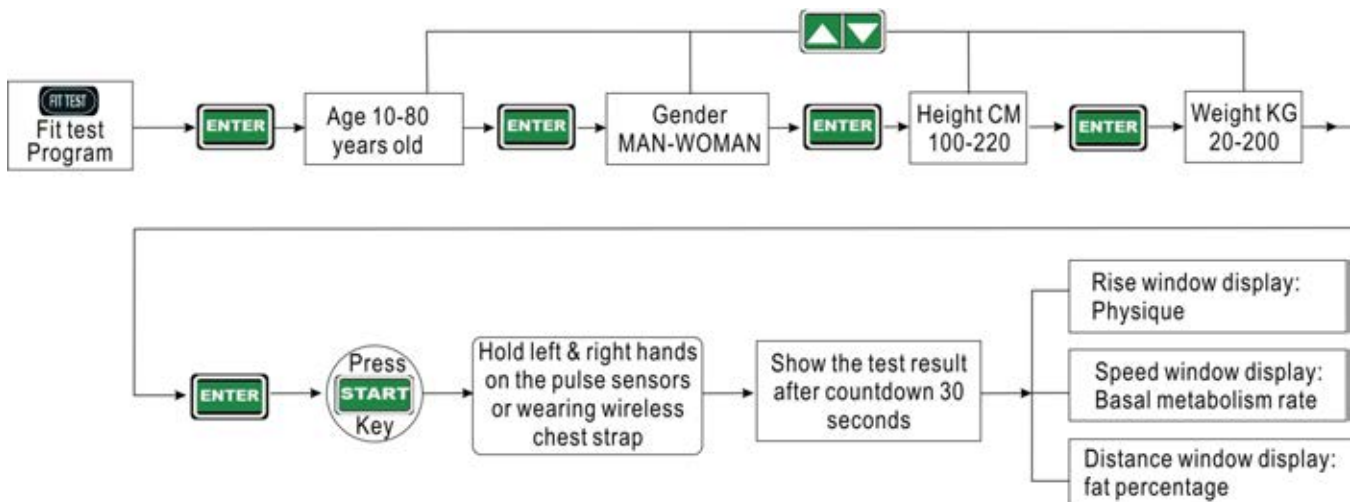

4.1.5 MP3 Playing and treadmill operation

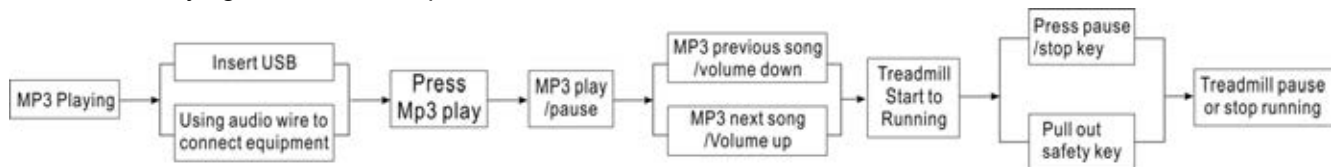

Warm tip: When you wearing special HRC wireless heart rate chest belt, do not play MP3 at the same time to avoid audio signal interfere with wireless heart rate

4.1.6 Program Matrix graphics and body mass index reference table

Custom program graphics

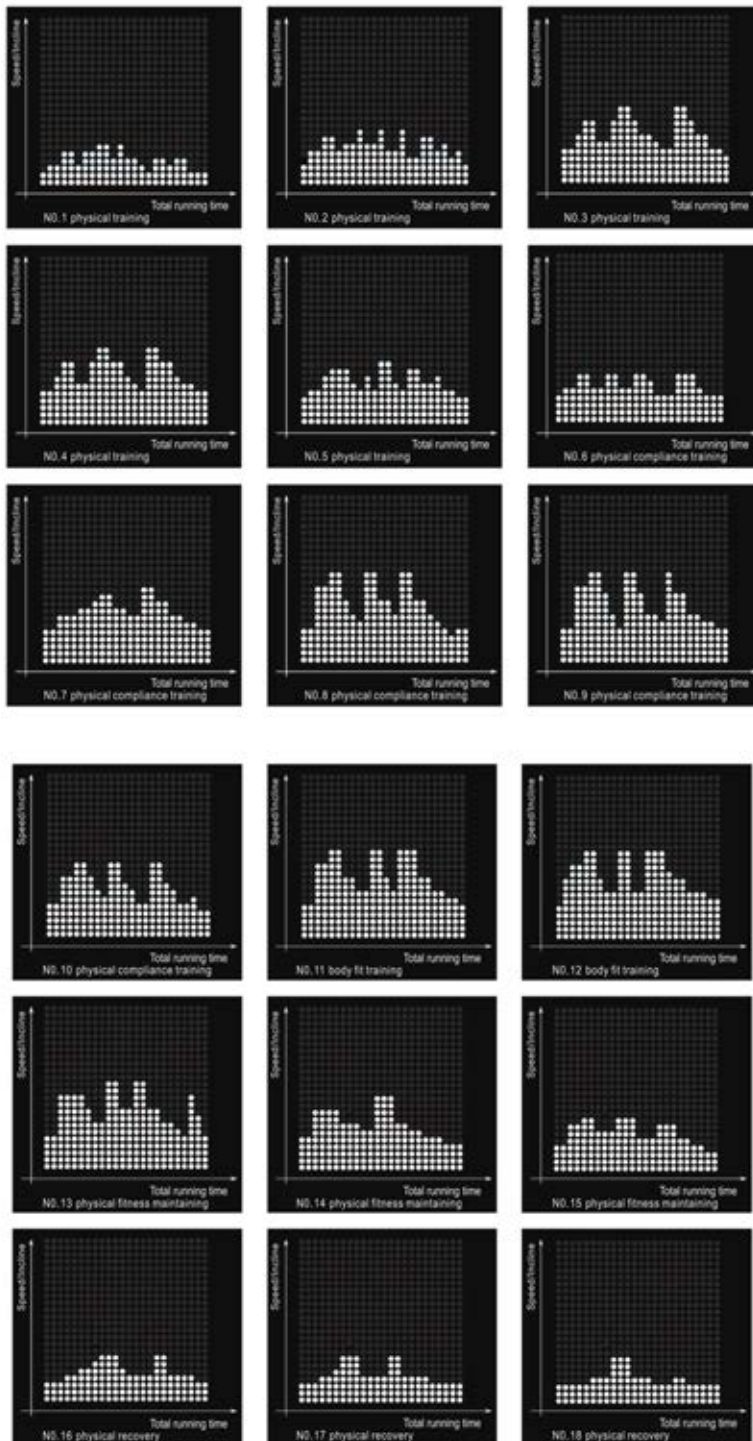

Hill climbing:

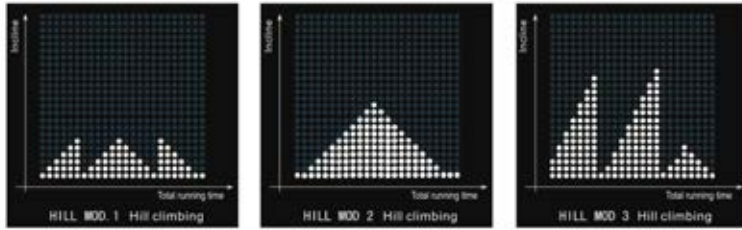

Fat percentage reference table

Age Gender	body shape	slim	healthy	fleshy	over wt	obese
	FAT%	body 1	body 2	body 3	body4	body 5
Male ≤30 years old		<14%	14%—20%	20. 1%—25%	25. 1%—35%	> 35%
Male > 30 years old		<17%	17%—23%	23. 1%—28%	28. 1—38%	> 38%
Female ≤30 years old		<17%	17%—24%	24. 1%—30%	30. 1—40%	> 40%
Female > 30 years old		<20%	20%—27%	27. 1%—33%	33. 1%—43%	> 43%

Adult body mass index(BMI) reference table

Body condition	Thin	Realistic weigt	Overweight	Mild obesity	Moderate obesity	Severely obesity
Body mass index(BMI)	< 18.5	18.5-23	23-25	25-30	30-35	>35

5. Hand pulse test

5.1 After and before exercise, can monitor exercise’s pulse of static and dynamic. The pulse will be restore after finished exercise. Exerciser hold the left and right hand touch pulse monitored metal, show pulse on screen. (Warm tip: the max pulse value do not over (220-age) when exercise. If over the max pulse, suggest to rest for 30 minutes, or reduce speed and incline. The test result is just for your exercise reference.)

6. Play music

6.1 Audio input

Using audio wire to connect treadmill audio interface 3.5mm and audio source (Mobile phone and tablet computer), the treadmill play audio from other audio source.

6.2 Local music playing

Put U disk into right USB interface to play the music from U disk.

7. Maintenance function

The treadmill have been Pre-lubricated before leave factory, it is not necessary to add lubricant oil when the treadmill running first time. In order to keep the treadmill operating at its best condition, the treadmill is equipped with oil adding reminding. When the treadmill running to 9000KM, LED will show “LUBRICATE”, it means need to add oil to the treadmill. After the first time oiling, the next reminding will display every 1000KM. Press “ENTER” to add oil and exit the reminding. Press “CLEAR” key to ignore lubricate temporarily, LED will show “LUBRICATE” after 50KMS.

The LED will show “REPLACE BELT” when the treadmill running every 25000KM totally, press “ENTER” to replace belt and exit the reminding, Press “CLEAR” to ignore replace belt temporarily, LED

will show "REPLACE BELT" after 50KMS



Oil adding reminding



replaces belt reminding

Maintenance and Malfunction Treatment

- 1) Clean: The surface of the treadmill should be kept clean, pull out the power line before cleaning. You can clean the running belt and the surface of the treadmill with a soft and wet cloth.
- 2) Adjust belt deviation: The running belt is adjusted at factory; it may runs defectively after transportation and use. Turn off the treadmill before adjusting, (see figure) adjust the pull the left and right bolts in rear roller with hex spanner. If the belt is deviation to left, clockwise rotate the left bolt. If the belt is deviation to right, counterclockwise rotate the right bolt. It is better to adjust 1/2 circle once. Then turn on the switch, check if the belt runs defectively when the running speed is 4~5 km/h. Repeat to adjust to the belt in the center.(see figure)
- 3) Adjust belt slip: After using for a long time, the belt may be longer and stuck. Your should adjust the left and right bolts in rear roller clockwise at same position till the runs smoothly and freely, it is better to adjust 1/2 circle once .But avoid to short belt using period of losses, doing not to adjust it too tight.

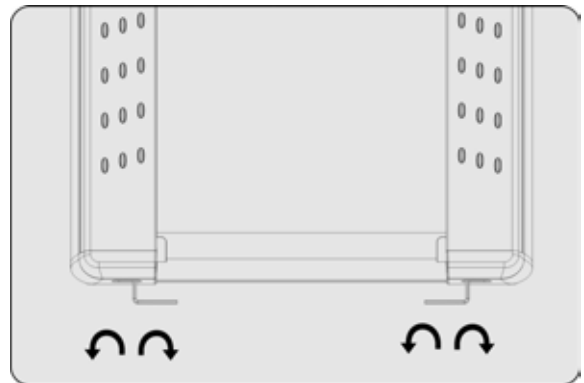



GARLANDO SPA
Via Regione Piemonte, 32 - Zona Industriale D1
15068 - Pozzolo Formigaro (AL) - Italy
contact@toorxprofessional.it
www.toorxprofessional.it